

# [404] TARADOUCHE SYSTEM



**DO NOT USE SOLVENT BASED NEOPRENE ADHESIVE TO GLUE THE COVING SYSTEM AND EXTERNAL CORNER SECTIONS OR ANY OTHER CORNER. GERFLOR RECOMMENDS**

**A POLYURETHANE RESIN BASED ONE-COMPONENT TRANSPARENT CONTACT ADHESIVE TEC 222 BY HB FULLER.**

<b>1 - WARRANTY .....</b>	<b>Page 116</b>
<b>2 - PRINCIPLE .....</b>	<b>Page 116</b>
2.1 - Definition	
2.2 - Floor/wall coverings	
2.3 - Products	
<b>3 - SUBSTRATES .....</b>	<b>Page 116</b>
<b>4 - CONSTRUCTIONAL MEASURES .....</b>	<b>Page 117</b>
<b>5 - FLOOR DRAIN .....</b>	<b>Page 118</b>
5.1 - NICOLL	
5.2 - Other drains	
5.3 - Timber substrate	
<b>6 - PREPARING CORNERS .....</b>	<b>Page 118</b>
<b>7 - INSTALLING THE FLOOR COVERING .....</b>	<b>Page 118</b>
7.1 - Substrate	
7.2 - Installation method	
7.3 - Installing the floor covering	
7.4 - Watertight sealing at edges	
7.5 - Treatment of joints	
7.6 - Shower / bedroom join	
<b>8 - INSTALLING THE WALL COVERING.....</b>	<b>Page 120</b>
8.1 - Substrate	
8.2 - Preparing the wall	
8.3 - Installing the wall covering	
8.4 - Overlap	
8.5 - Wall-hung WC	
8.6 - Finishing - Connections	
<b>9 - APPENDIX - TARADOUCHE COMFORT PLUS SYSTEM.....</b>	<b>Page 122</b>
<b>10 - LIST OF SPECIAL TOOLS .....</b>	<b>Page 123</b>
<b>11 - ACCESSORIES .....</b>	<b>Page 123</b>

## [404] TARADOUCHE SYSTEM

All floor and wall coverings should be examined prior to installation for any problems of a visual nature. If there are any visible defects, please notify Belgotex and do not begin installation without its agreement.

### 1. WARRANTY

#### ■ 1.1 - PRODUCT WARRANTY

Floor and wall coverings must be installed in accordance with the Technical Notice, the Specification current on the contract signature date and with accepted best practice. In this case, the floor and wall coverings will be covered by the manufacturer's warranty.

#### ■ 1.2 - INSTALLATION WARRANTY

As this process is detailed in a Technical Notice and classed in the "green" list (low risk not requiring any additional insurance premium) of the AQC Commission (Manufacturer Quality Assurance), contractors are not obliged to take out any special insurance policy.

#### ■ 1.3 TRAINING AND SUPPORT

The company GERFLOR:

- Offers specific training sessions on installation of Shower floor and wall coverings with the award of individual certificates
- Is able to intervene at the request of the enterprise responsible for the work
- Is able to assist the enterprise responsible for the work at the start of the project if requested.

### 2. PRINCIPLE

#### ■ 2.1 - DEFINITION

Complete shower system based on PVC floor and wall coverings including use of floor drains and creation of slopes.

#### ■ 2.2 - FLOOR/WALL COVERINGS

Flexible reinforced vinyl floor coverings in rolls and NF-UPEC certified as follows:

Commercial name	Classification	Thickness	Fire rating
TARASAFE H <sub>2</sub> O	U4P3E2/3C2	2 to 2,2 mm	C <sub>fl</sub> -s1
TARASAFE	U4P3E2/3C2		B <sub>fl</sub> -s1 (equivalent to M3 on MO substrate)
ELEGANCE SD	U4P3E2/3C2		

#### Flexible reinforced vinyl wall covering in rolls:

Commercial name	Thickness	Fire rating
MURAL CALYPSO	0,9 mm	B-s2, d0 on M1 substrate

#### ■ 2.3 - PRODUCTS

- Floor drains
  - Cove formers
  - Adhesives
  - Weld rods
  - Capping strip
  - Sealing products
  - Tarafoam 20 foam for the Comfort version of the shower system
- All surfaces (floors and walls up to the ceiling) will be treated with this complete system.**

### 3. SUBSTRATES

#### BARE SUBSTRATES FOR FLOOR COVERINGS

SUBSTRATE TYPE	STANDARDS
Slab laid directly on ground	Applicable local standards
Solid slab floors of cast in-situ concrete, continuous at supports	NF P 18 201, applicable local standards
Solid slab floors made of prefabricated pre-slabs and concrete cast in-situ, continuous at supports	CSTB specification 3221 May 2000 NF P 18 201, applicable local standards
Floors made of reinforced concrete hollow core slabs, with a topping layer continuous at supports	NF P 18 201, applicable local standards
Floors made of prestressed concrete hollow core slabs, with a topping layer continuous at supports	CSTB specification 2892 June 1996
Ribbed floors with prefabricated beams combined with cast concrete or combined with other prefabricated components and concrete cast in-situ, continuous at supports	CSTB specification 2920 November 1996
Floors of concrete cast in-situ on wide metal strips acting compositely, continuous at supports	Respective Technical Notices supplemented by addenda supplemented by common addendum no. 3 / 94 - 258
Conventional hydraulic binder-based screeds or slabs	NF P 14 201, applicable local standards
Cement-based liquid screeds	Respective Technical Notices
Solid and wood-faced floors (wood on joists)	NF P 63 201, applicable local standards
Floors of wood-based panels in EB+ private premises only	NF P 63 203, applicable local standards

# [404] TARADOUCHE SYSTEM

## WALLS

### PERMISSIBLE WALL SUBSTRATES BASED ON EXPOSURE TO WATER

SUBSTRATE PREMISES	Concrete		Cement-based coating	Gypsum-based coating		Partition wall or wall lining		Partition wall with gypsum blocks			Ceramic tiled partition wall		Masonry of cellular concrete blocks	
	S1	S2	S3	S4	S5	S6	S7	S8	S9	S10	S11	S12	S13	S14
EA														
EB + private	(1)		(3)			(8)					(4)	(5)	(6)	(6)
EB + collective	(2)	(2)	(3)									(5)	(6)	(6)
EC	(2)(7)	(2)(7)	(3)(7)									(5)(7)	(6)(7)	(6)(7)

### DESCRIPTION AND REQUIREMENTS

(1) coated with a type S5 smooth-finish coating or gypsum- or cement-based smooth-finish levelling compound

(2) coated with a smooth-finish coating or cement-based smooth-finish levelling compound

(3) denibbed and/or coated with a smooth-finish cement-based levelling compound (as per applicable local standards)

Substrate not permitted

(4) S11 with gypsum-based finish hardness > 60

(5) S12 coated with a smooth-finish cement-based special coating (as per applicable local standards) described in the Technical Notice for the substrate

(6) coated with a smooth-finish cement-based special coating for cellular concrete (as per applicable local standards)

(7) EC premises: installation of TARASAFE PLUS only

(8) S6: These substrates are only permitted in renovation work and in the case of existing painted panels, subject to carrying out suitable preparation after prior survey.

 Substrate permitted for direct glue-down

 Substrate not permitted

#### • Wall substrates:

- S 1 - NFP 18.210-1 (applicable local standards) regular poured concrete walls
- S 2 - NFP 10.210-1 (applicable local standards) refined surface poured concrete walls
- S 3 - NFP 15.201-1 (applicable local standards) mortar coatings
- S 4 - NFP 12.301 plaster for interior coatings hardness > 40
- S 5 - NFP 71.201 (applicable local standards) plaster for interior coatings hardness > 60
- S 6 - NFP 72.302 plasterboard panels

NFP 72.203 -1-(applicable local standards)

NFP 72.204 -1-(applicable local standards)

- S 7 - water-repellent plasterboard panels
- S 8 - NFP 72.301 gypsum blocks
- S 9 - water-repellent gypsum blocks
- S10 - extra water-repellent gypsum blocks
- S11 - ceramic tiles (gypsum-based adhesive binder)
- S12 - ceramic tiles (cement-based adhesive binder)
- S13 - NFP 14.306 - Cellular concrete blocks
- S14 - Partition wall of cellular concrete panels

#### • Classification:

EA premises: Dry premises

EB premises: Moderately damp rooms (WC, etc.)

EB+private premises (on slab and cement or wood based floors):

Shower enclosure, private bathroom

EB+collective premises (on slab and cement based floors):

Individual shower for collective use in premises of the type: residential school, collective changing room, collective washing facilities not commercial in character, washing facilities accessible to the public.

EC premises: Very damp premises (collective showers, sports changing rooms): TARASAFE PLUS on the floor only. Gluing down with a reactive two-component adhesive. For the wall: MURAL CALYPSO.

## 4. CONSTRUCTIONAL MEASURES

Special constructional measures must be taken and complied with to ensure correct installation and water tightness of the TARADOUCHE PLUS SYSTEM employing a coving system solution.

### ■ 4.1 - ABOUT SUBSTRATES

FLOOR substrate with slope to drain (1%).

- Splash protection
- Right-angled, well finished wall-floor angle
- There must be no expansion joints crossing the area concerned
- Substrates (walls / partitions)

Taken from DTU 59.4: Substrates must be free of water stains, mould and marks (marker lines, ink or pencil lines, graffiti, etc.). Evenness and vertical trueness of walls must comply with applicable local standards.

#### Extract from Technical Notice:

slope of at least 1% in the area exposed to water; the slope must be created at least in the shower area delimited by the vertical wall(s) and in the entire area that is not splash-protected and therefore exposed to water; in other words at least 1.80 m from the hose attachment and from the centre line of the drain; given the limited surface area of showers, the slope is generally over the entire surface;

- threshold with chamfered or rounded edges of between 1 and 2 cm opposite the door threshold to prevent water leaving the bathroom when the door is positioned between 1.20 m and 1.80 m from the drain or from the shower hose attachment;
- furthermore, the door must not be situated less than 1.20 m from the shower head attachment point. In cases where water splashes are contained in a surface area delimited by rigid walls, fixed or moveable, the following design requirements are to be applied:
- the wall height must be at least 1.80 m;
- if this surface area is delimited by an threshold of 1 to 2 cm, the slope and watertight sealing are then executed only on this surface area.

### ■ 4.2 - ABOUT THE DRAIN

On water-bound substrate: the plumber should supply and install the drain (at finished slab level at least 30 cm from walls from the centre line of the drain) in coordination with building and flooring contractors.

On timber substrate: the plumber should supply and install the drain (at wood panel level at least 30 cm from walls from the centre line of the drain: fit and tighten the frame and then tighten the drain on the frame) in coordination with the woodwork / timber framing and flooring contractors.

### ■ 4.3 - ABOUT PIPEWORK

#### 4.3.1 - FLOOR

The following solutions are envisaged:

- Position inside the partition wall
- Pass through a common utility conduit
- Pass through an adjacent room
- Locate together in a corner + boxing in
- Feed down from the ceiling

#### 4.3.2 - WALL

Taken from DTU 59.4: The substrates must be free of water stains, mould and inscriptions (chalk lines, ink or pencil lines, graffiti, etc.).

Supply and waste pipes for future connection must extend by no more than 5 cm, and the space between pipework and wall should be 5 cm (for installation of MURAL CALYPSO).

### ■ 4.4 - ABOUT SANITARY WARE

- Wall mounting of sanitary ware: wash basin, etc.
- Wall mounting advised: WC
- Horizontal waste outlet mandatory
- Sanitary ware should not be already mounted (technical contractors must arrange for removal and replacement)

## [404] TARADOUCHE SYSTEM

### 5. FLOOR DRAIN

#### Installing the drain

The drain is supplied and fitted by the plumber at finished concrete slab level at least 30 cm from walls from the centre line of the drain.

The following models are recommended:

#### ■ 5.1 - GERFLOR

##### Ref PVC Drain with STAINLESS STEEL grill no. H 090

Ø114 mm vertical outlet Ø35 x Ø40 mm

Can be adapted for horizontal outlet.

#### ■ 5.2 - NICOLL - REF: SITAR OR SITAR V

Both drains are available from GERFLOR.

Two outlet diameters: Ø 50 mm - Ø 63 mm

Two types: horizontal Ø 50 mm - vertical Ø 50 mm and Ø 63 mm

#### ■ 5.3 - ON TIMBER SUBSTRATE:

The drain is supplied and fitted by the plumber on a **reinforcing plate resting** on a header joist in the timber framing at the level of the wood panels at least 30 cm from the walls from the centre line of the drain.

#### PVC DRAIN WITH SS GRILL - H 090

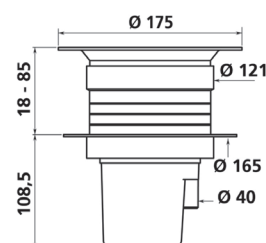
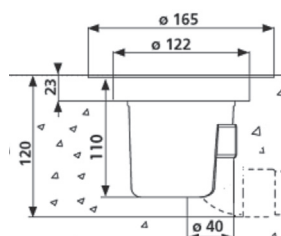

#### SITAR DRAIN - H112

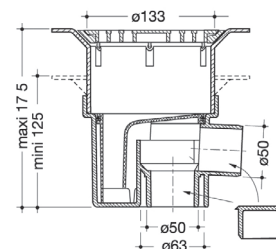

#### SITAR V DRAIN - H113

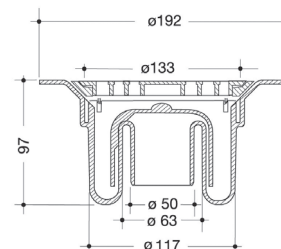

### 6. PREPARING CORNERS

#### Cove former (available from GERFLOR) ref.0478

To be glued onto substrates or on foam in the case of installation on soundproofing layer.

Use a polyurethane resin based one-component transparent contact adhesive TEC 222 by HB FULLER or double-sided adhesive tape or a water based contact adhesive.

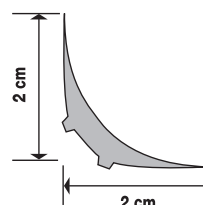

### 7. INSTALLING THE FLOOR COVERING

#### ■ 7.1 - SUBSTRATE

Acceptance of the substrate is carried out in accordance with NF P 62-203-2 (applicable local standards) taking account of the slope of the substrate over the entire area of the premises.

Laying by gluing down the floor covering in lengths is carried out on a substrate implemented in accordance with NF P 62-203-2 (Special Provisions of DTU 53-2: Bonded Plastic Floor Coverings).

#### ■ 7.2 - INSTALLATION METHOD

Deployment of a coving system solution for GERFLOR floor coverings.

#### ■ 7.3 - INSTALLING THE FLOOR COVERING

##### 7.3.1 - Laying the floor covering

- Minimum ambient installation temperature: 10°C.
- Minimum substrate temperature: 10°C.

##### 7.3.2 - Layout - Preparation of lengths

- Lay the lengths out edge to edge so that welds are more than 20 cm from the drain.
- It is advisable not to have any welds in the shower area.

##### 7.3.3 - Gluing\*

- Gluing takes place 24 hours after the lengths are positioned in place.
- The flooring is installed simply by gluing down using acrylic emulsion adhesive applied with a finely-serrated spatula with a coverage of about 300/350 g/m<sup>2</sup>, type A2 (as per TKB specification). The spatula will need to be changed regularly to maintain this coverage.

#### A2 Type Spatula

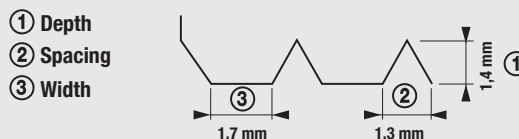

#### \* Recommendations for gluing:

- Carefully follow the instructions provided by the adhesive supplier.
- Ensure compliance with the waiting time which depends on the temperature, the atmospheric conditions of the room, the substrate's porosity and the coverage of the adhesive used.
- If flooring is applied to adhesive having allowed inadequate waiting time then blisters will form.
- If flooring is laid onto adhesive whose working time is exceeded, there will be poor transfer of adhesive to the back of the material (poor adhesion).

#### 7.3.4 - Laying the lengths

- Fold back half the length. Glue the substrate and apply the flooring.
- Fold back the other half and proceed in the same way, leaving play of 1 mm.
- Do not overlap two adhesive films when you apply more adhesive.

# [404] TARADOUCHE SYSTEM

## 7.3.5 - SMOOTHING

- Careful manual smoothing during laying to ensure correct transfer of the adhesive film.

### Important

- Foot traffic 24 hours after laying.
- Do not install fittings or furniture until 48 hours after laying.
- Do not use furniture items with rubber feet.

## 7.3.6 - Water-tightness of floor covering/drain join

- Unroll and glue the GERFLOR floor covering up to the screw plate. Double acrylic gluing around the drain is recommended.
- Lay the lengths out edge to edge so that welds are more than 20 cm from the edge of the drain.

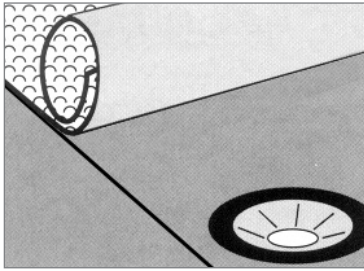

- Draw the cutting circle inside the flange positioned above the hole.

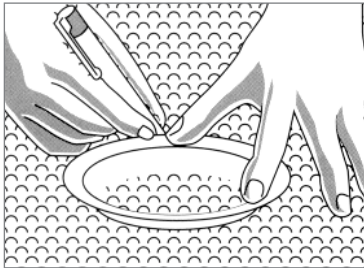

- Cut the floor covering

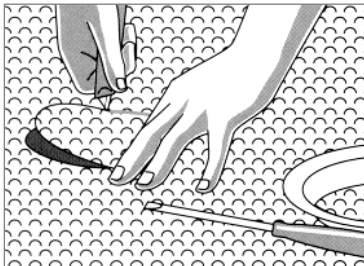

- Heat the material using a hot air tool.

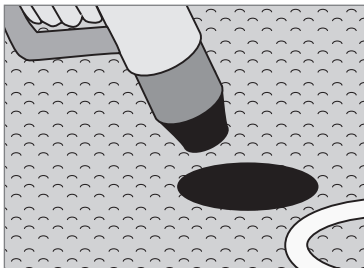

- Position the flange on top.
- Fix it with screws.

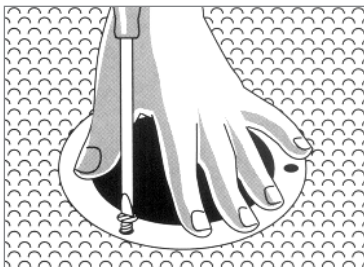

## 7.4 - WATERTIGHT SEALING AT EDGES IN CORNER

### 7.4.1 - By coving system

#### INTERNAL CORNER

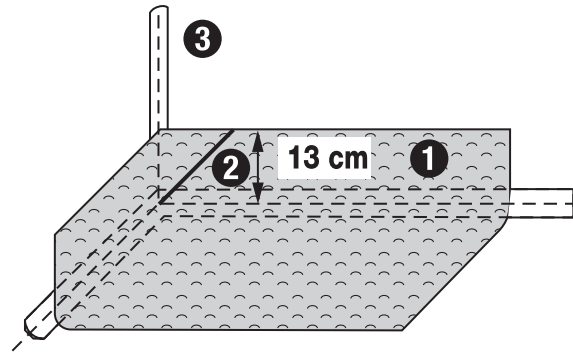

1. Glue the floor covering on the wall up to 13 cm.
2. Cut the floor covering at 45° and weld using CR 40 rod.
3. WALL corner: fix by double gluing the CA 12 corner bead over the full height from the coving system.

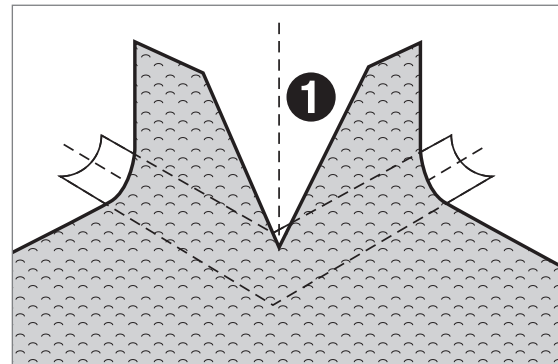

#### EXTERNAL CORNER

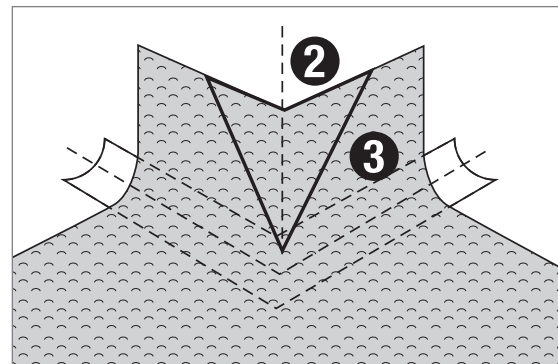

- 1- Cut the floor covering up to the mid-height of the cove former.
- 2- Add a piece of floor covering.
- 3- Weld with CR 40 weld rod and trim.

Gluing of coved corners can be done using translucent PU contact adhesive by HB Fuller TEC 222 or a water based contact adhesive or double-sided adhesive tape. GERFLOR recommends that you refer to the technical data sheets for the adhesives or adhesive tapes for instructions on their use.

## [404] TARADOUCHE SYSTEM

### 7.5 - TREATMENT OF JOINTS

No welding on the drain

- Heat welding is mandatory (at least 24 h after gluing).

#### Chamfering

Chamfering allows the joint to be opened and adjusted, to remove any traces of adhesive that may impair the quality of the weld:

- It is executed using an appropriate tool.
- Chamfering should be executed over the thickness of the floor covering minus about 0.3 mm.



Triangular scraper, Ref: 95185 by ROMUS



Linea Groover, Ref: 95101 by ROMUS



Triangular scraper, Ref: 95185 by ROMUS



Swift Groover Ref: 262 611 400 by Janser

### 7.6 - SHOWER / BEDROOM JOIN (REF. 0469)

#### 7.6.1 Join with a PVC shower threshold

Packaging (0469): 8 X 3 ml

Installation: Gluing of shower thresholds can be done using translucent PU contact adhesive by HB Fuller TEC 222 or a water based contact adhesive or double-sided adhesive tape.

**Gerflor recommends that you refer to the technical data sheets for the glues or adhesives for instructions on their use.**

#### 7.6.2 For a join with another rubber or linoleum floor covering

Sealing with a MS POLYMER sealant, on shower and bedroom side.

#### Welding of GERFLOR floor coverings

Welding is with a LEISTER type adjustable hot air gun with suitable speed nozzle.

It is also possible to weld with the speed welding nozzle (Ø 5 mm). For all types of welding equipment, follow the manufacturer's instructions.

#### Trimming of GERFLOR floor coverings

This operation should be done after the weld seam has cooled with:

- either a trimming tool
- or a flexible spatula sharpened in the middle

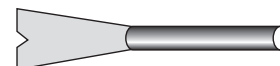

#### IMPORTANT!

GERFLOR is at your disposal for any further information on equipment.

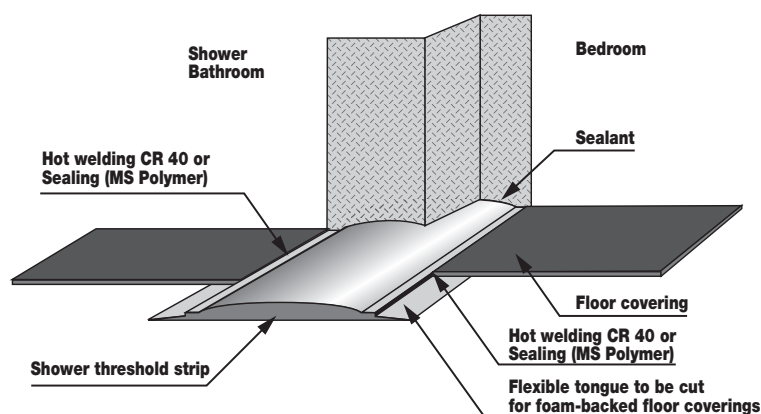
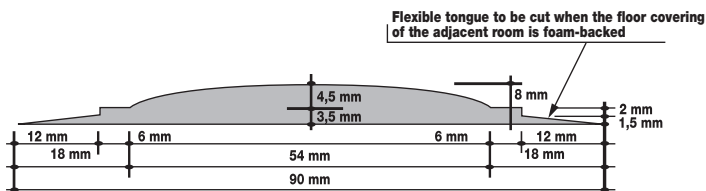

#### 7.6.3 For a join with a rubber shower threshold

Sealing with a MS POLYMER sealant, on shower and bedroom side.

Sealing should also be done around bottom of door frames.

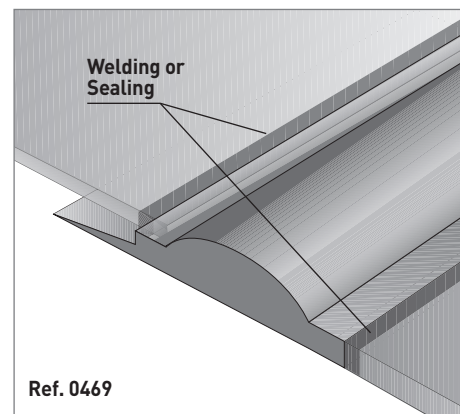

## 8. INSTALLING THE WALL COVERING: MURAL CALYPSO

### 8.1 - SUBSTRATE

Installation by gluing of the wall covering in lengths is carried out on a substrate implemented in accordance with:

- applicable local standards
- The Technical Notice for the substrates concerned
- The GERFLOR installation guide "Preparation of substrates for wall coverings".

#### Recap of Requirements:

Taken from DTU 59.4: The substrates must be free of water stains, mould and inscriptions (chalk lines, ink or pencil lines, graffiti, etc.).

- After light sanding and dust removal, the coating must not show any chalking, chapping, cracks, holes or streaks greater than or equivalent to 1 mm.

- Local evenness: 1 mm under 20 cm straight-edge.
- Overall evenness: 5 mm under 2.00 m straight-edge.
- Vertical trueness: 5 mm under 2.50 m straight-edge.
- Mean hardness: 45 shore C.
- Moisture content less than 5% by weight.

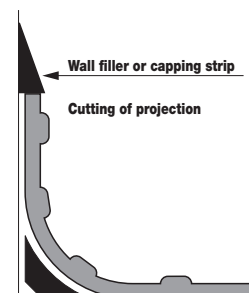

# [404] TARADOUCHE SYSTEM

## 8.2 - PREPARING THE CONNECTION ON THE COVING SYSTEM

Projections under the overlap will be cut using a trimming plane or quarter moon cutter. The difference in thickness is made up for by feathering with filler or by a capping strip.

### INTERNAL CORNER: 1

Glue a CA12 corner bead in the corner before installing the MURAL CALYPSO wall covering.

### EXTERNAL AND OBTUSE CORNER > 90°: 2-3

For external and obtuse corners >90°, double gluing with water based contact adhesive is needed to prevent loss of adherence over time. Use of double-sided adhesive tape is possible if the tape's manufacturer is in agreement and guarantees it for this use.



## 8.3 - INSTALLING MURAL CALYPSO ON FULL HEIGHT

The lengths can be laid vertically or horizontally. If there is a false ceiling, install MURAL CALYPSO before fitting corner protection. Sealing may be required on the layer of material above the false ceiling.

For horizontal laying the material should be unrolled to reach a height of 1.95 m from the top of the coving keeping at least 3 cm overlap with the Taradouche floor covering.

Then add a strip starting from the ceiling or false ceiling creating an overlap of 3 cm.

### 8.3.1 - Installation and storage temperature

- For vertical and horizontal laying, cut the lengths at least the day before.
- Minimum substrate temperature: 10°C
- Minimum ambient installation temperature: 10°C.
- Store the wall covering at the minimum installation temperature (15°C) for 24 hours.

### 8.3.2 - Marking guidelines

#### Vertical laying:

Draw an initial plumb line positioned according to the dimensions of the room so as to avoid any welding close to (within >10 cm) or at a corner.

#### Horizontal laying:

Draw a line at 1.95 m from the coving all around the edges of the bathroom.

### 8.3.3 - Gluing

Application as a single coat of water based dispersion adhesive (acrylic) with a type A4 finely serrated spatula (as per TKB recommendation) and crossed with a medium length pile roller or applied directly with the medium length pile roller.

\* Recommendations for gluing

- Carefully follow the instructions provided by the adhesive supplier.
- Carefully respect the waiting time which depends on the temperature, the atmospheric conditions of the room, the substrate's porosity and the coverage of the adhesive used.

### 8.3.4 - Applying adhesive to the substrate and laying the lengths

#### 8.3.4.1 - Gluing for vertical installation

Glue over the entire height up to the ceiling

#### 8.3.4.2 - Gluing for horizontal installation

Glue only up to the specified height for application of the length.

Gluing of the strip will be done only after installation of the horizontal length.

### 8.3.4.3 - Gluing of corners:

#### INTERNAL CORNER: 1

Glue CA12 corner bead with acrylic adhesive in the corner before installing the MURAL CALYPSO wall covering.

#### EXTERNAL AND OBTUSE CORNER > 90°: 2-3

For external and obtuse corners >90°, double gluing with water based contact adhesive is needed to prevent loss of adherence over time. Use of double-sided adhesive tape is possible if the tape's manufacturer is in agreement and guarantees it for this use.

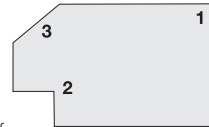

### 8.3.5 - Laying the lengths

#### 8.3.5.1 - Vertical installation

Cut the length the day before allowing a margin (at least 10 cm) Lay the lengths avoiding any welds in the shower area.

#### 8.3.5.2 - Horizontal installation

##### 8.3.5.2.1 - Laying a length

Cut the length the day before allowing a margin (at least 10 cm) Draw a horizontal guide line at 1.95 m from the top of the coving all around the edges of the room.

Draw a vertical marker line on the entire height of the wall opposite the door. On the top edge of the material make a mark corresponding to the middle of the length before rolling it in on both sides. Unroll one of the rolled-in sides following the horizontal guide line smoothing it as you work. Proceed in the same way for the second side.

##### 8.3.5.2.2 - Laying the upper strip:

Cut the strip the day before allowing a margin both lengthwise and width-wise. Draw a horizontal guide line 3 cm below the edge of the laid length so as to obtain an even overlap. Place protective paper underneath this horizontal guide line to prevent traces of adhesive on the length already laid. Glue the upper part and also the 3 cm overlap. Unroll the strip proceeding in the same way as for the length and making the weld above the door.

### 8.3.6 - Smoothing

#### a) During fixing

Remove air pockets from top to bottom and from centre to edges using a cork pressing block.

#### For external corners:

- Smooth up to the corner.
- Wrap the wall covering around while smoothing out the corner and finish with the external corner roller.

#### For internal and obtuse corners:

Bring the wall covering to the corner smoothing it with the internal corner roller.

#### b) Final smoothing

Using a cork pressing block smooth the entire surface. In order to prevent a stretched effect at internal corners we do not recommend heating the material.

### 8.3.7 - Trimming

Trim the material along the ceiling or false-ceiling.

We recommend sealing after trimming with a MS Polymer sealant.

### 8.3.8 - Treatment of joints (24 hours after gluing)

LAYING THE LENGTHS	MURAL CALYPSO. SPACING BETWEEN LENGTHS: 1 MM + 0.5 - 0MM	
	Tools	Use
Chamfering		Ensure that joints are even. Remove traces of adhesive which may prevent fusion of the weld rod.
	Triangular scraper	The shallow thickness of the material means that each edge needs to be chamfered separately using a triangular scraper tilted right and then left. This method increases the contact area of the CR 41 rod when welding.
Welding	HOT JET S type fitted with a RAPID ULTRA nozzle	CR 41 weld rod. Airflow output: position 4 (80 l air / min) / Temperature: 450° to 500°, position between 4 and 5.
	LEISTER TRIAC fitted with a VENTED nozzle	Airflow output: 230 l/min. Temperature: position between 4 and 5. The vented nozzle should be cleaned after each weld.
Levelling/trimming	SLIM or MOZART levelling spatula Quarter moon cutter + levelling guide	Use a levelling spatula sharpened only in the middle so as not to cut into the material.

## [404] TARADOUCHE SYSTEM

### 8.4 - OVERLAPPING THE COVING (OR EDGING)

The wall covering overlaps the coving of the floor covering by 3 cm. MURAL CALYPSO is glued to the coving with acrylic adhesive.

1: The difference in thickness is made up for by feathering with wall filler or a capping strip.

2: Remove projections with a 1/4 moon cutter over 3 cm.

3: The floor covering under the overlap should be protected with masking tape.

4: Apply the adhesive. Remove the masking tape before applying the MURAL CALYPSO.

Heat and smooth MURAL CALYPSO on the overlap using a flat roller.

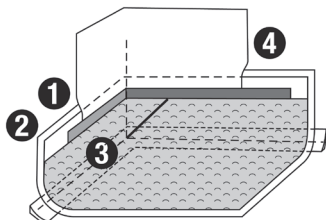

### 8.5 - WALL-MOUNTED WC

- This type of fitting should be installed in accordance with the bathroom fitting and frame-substrate standard XP D 12-208.
- WC bowls should be fixed onto two BA 13 panels glued together or on BA 25 or on BA 18 extra hard.

NOTE: Gluing and cutting of MURAL CALYPSO around WC fittings must be done with great care and comply with our recommendations.

Reminder: A4 spatula, coverage: approx. : 150/200 g/m<sup>2</sup>, crossed with a medium length pile roller, final smoothing with heat gun and cork pressing block.

In the case of a wall-hung WC, and in the absence of any specific reinforcement, there is a potential risk of blistering on the wall covering at the join of the WC with the plasterboard substrate owing to tightening of the fixings and risk of gradual bending of the substrate; insertion of a rigid sheet of the contractor's choice is one solution for improving wall rigidity and may reduce this risk.

For all other cases, please consult us: Tel.: +33 (0)4 74 05 40 08 / + 33 (0)4 74 05 45 78

### 8.6 - FINISHING - CONNECTION WITH UTILITIES / SERVICES INFRASTRUCTURE

Gluing, cutting and finishing of MURAL CALYPSO around utilities/ services infrastructure must be executed with particular care and comply with our recommendations.

#### 8.6.1 Wall fittings

Sealing of wall fittings should be included in the plumbing work on installation of wash basins, bathroom cabinets, wall mounted cisterns, grab handles, inspection hatches, etc.

Sealing - ref: BOSTIK MS 107

#### 8.6.2 - Services through walls (heating, plumbing)

Sealing of services through walls should be included in the plumbing work.

HW/CW inlet: : shower, wash basin - Soil pipes: grey water / black water Sealing - ref: BOSTIK MS 107

#### 8.6.3 - Bathroom edges

Bottom of door frames - window - around false ceiling edges (when MURAL CALYPSO is fitted afterwards).

Sealing - ref: BOSTIK MS 107

Door threshold: heat welding with plastic floor covering of adjacent room or on shower threshold strip [bedroom, corridor] see 6.6.

#### 8.6.4 - Electricity

Switch - Socket

Cf. standard NFC 15-100 (amendment May 1991)

Minimum distance (in France) between an electric point and a fixed shower head or shower hose attachment: 1.20 m.

#### 8.6.5 - Ventilation

Natural: low inlet / high inlet

Mechanical: wall/ ceiling outlet

Sealing - ref: BOSTIK MS 107

#### 8.6.6 - Special cases - Renovation

(see 3.3.1 floor)

Horizontal and vertical pipe runs - Fixing of bathroom fittings. taires.

Grouped services

Location of pipes together in a corner and full height boxing in.

Special case: Horizontal sealing around pipes in renovation works.

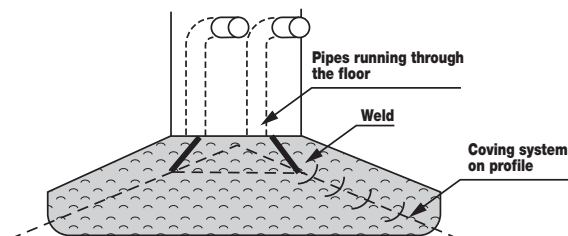

The MS POLYMER sealing solution may be acceptable in certain renovation cases around hot and cold water inlets and wash basin

waste pipes, heating pipes, vertical WC outlets on condition that they are outside the shower's water splash range.

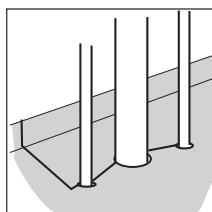

CUTTING OF MATERIAL AROUND PIPES AND WELDING

## 9. APPENDIX - TARADOUCHE COMFORT PLUS SYSTEM ONLY FOR INSTALLATION OF TARASAFE H<sub>2</sub>O AND TARASAFE SD

### 9.1 - FITTING SOUNDPROOF UNDERLAY

- The TARAFOAM underlay is installed at least 24 hours before the shower floor covering.
- Lay the foam flat with the reinforced surface that will be in contact with the floor covering uppermost.
- The foam is laid edge to edge
- The foam is glued with a water based contact dispersion adhesive (acrylic) applied with a TKB standard A2 spatula
- Cut and trim around edges
- Cut around the drain, allowing about 1 cm
- Glue the cove former to the TARAFOAM underlay

### 9.2 - INSTALLING THE FLOOR COVERING

Glue the floor covering onto the underlay using a compact/compact acrylic adhesive at 200 to 250 g/m<sup>2</sup> with type A5 spatula (TKB specification), then flatten ridges in the adhesive with a medium length pile roller. (The waiting time MUST be complied with for this type of gluing). Install the floor covering following the same principle as for the TARADOUCHE PLUS System.



# [404] TARADOUCHE SYSTEM

## 10. LIST OF SPECIAL TOOLS

### ROMUS

ZA des Pouards 13 et 15 rue du Taillefer  
B.P. 291 - 91162 LONGJUMEAU CEDEX  
Tél. : 01 69 79 69 79 - Fax. : 01 64 48 41 00  
e-mail : commercial@dromus.fr

### JANSER S.A.

Parc d'activités de la Mossig  
B.P. 18 - 67521 MARLENHEIM CEDEX  
Tél. : 03 88 59 28 20  
Fax : 03 88 59 28 22

### WOLFF

4, avenue du Président Coty  
02880 CROUY  
Tél. : 03 23 76 37 52  
Fax. : 03 23 76 37 51

	ROMUS	JANSER	WOLFF
WALL SCRIBER - max. height 200 mm	Ref. : 95430	Ref. : 222 430 100	
Gluing spatula with interchangeable blade (18 cm)	See catalogue		
A 2 blade TKB Standard			
A 4 blade TKB Standard			
PRESSURE ROLLER - steel $\varnothing$ 30 x 45 mm		Ref. : 224 400 125	Ref. : 111 200 000
COVING RULER - For cutting floor coverings at 13 cm and 10 cm from floor, at coving height		Ref. : 224 432 000	
CORK PRESSING BLOCK FOR SMOOTHING	Ref. : 93145	Ref. : 262 380 000	Ref. : 720 930 000
COMBINED TRACER AND MARKING GAUGE - (spur 1 mm thick)	Ref. : 09335	Ref. : 262 130 500	
SPARE BLADE (in 5s)	Ref. : 93356	Ref. : 262 415 001	
SPARE POINT $\varnothing$ 1.5 mm (in 20s)	Ref. : 93357	Ref. : 262 126 000	
ROLLER FOR INTERNAL CORNERS	Ref. : 093135	Ref. : 224 400 123	Ref. : 116 340 000
ROLLER FOR EXTERNAL CORNERS		Ref. : 262 614 000	Ref. : 116 350 000
TRIMMING TOOL for Coving	Ref. : 95103	Ref. : 262 635 000	
RAPID ULTRA NOZZLE	Ref. : 95027	Ref. : 224 800 007	
VENTED NOZZLE	Ref. : 95030	Ref. : 224 700 300	
TRIANGULAR SCRAPER	Ref. : 95185		
LINEA GROOVER	Ref. : 95101		
MASTER TURBO	Ref. : 95200		
SWIFT GROOVER		Ref. : 262 611 400	
TRIMMING SPATULA - For trimming floor coverings with projections		Ref. : 262 609 100	Ref. : 116 400 000 Ref. : 116 402 000
PRESSURE BALL - Brass - $\varnothing$ 13 mm - For rounding joints in corners		Ref. : 224 816 000	Ref. : 116 200 000
ROUND FILE $\varnothing$ 4 mm - For sharpening trimming spatulas and cleaning vented nozzles	Ref. : 95191	Ref. : 262 609 102	

## 11. ACCESSORIES

### 12.1 - ACCESSORIES AVAILABLE FROM GERFLOR

#### DRAINS: STAINLESS STEEL GRILL / SITAR / SITAR V

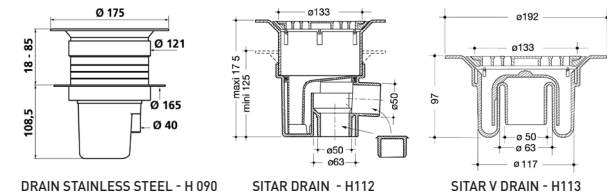

#### CORNER BEAD CA 12 (H204)

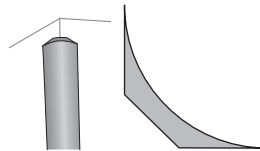

#### COVE FORMER (0478)

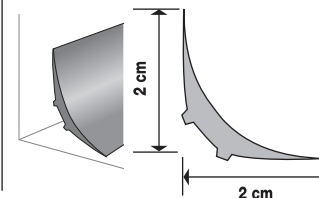

#### CAPPING STRIP (0490)

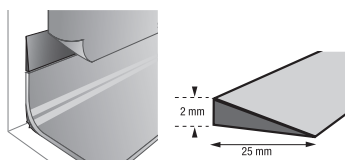

#### SHOWER THRESHOLD (0469)

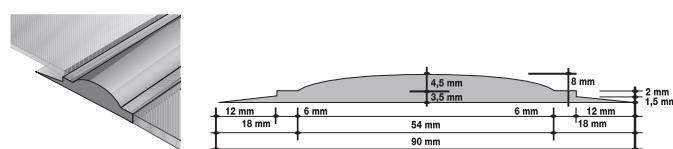

### 12.2 - OTHER RECOMMENDED ACCESSORIES, BUT NOT AVAILABLE FROM GERFLOR

SEALANT - BOSTIK SA - Tel.: + 33 (0)1 64 42 12 12 - Ref.: POLYMER MS107 by BOSTIK