

[403] LAYING TECHNIQUES FOR MURAL ULTRA / MURAL CLUB / MURAL CALYPSO



In accordance with the local standards

Before fixing the cladding, examine it to detect any problems of a visual nature. If there is an aspect defect, inform Belgotex and do not start laying without its agreement.

1 - SUBSTRATES

The preparation of the wall substrate must be in accordance with local standards.

Levelness and flatness must be checked and corrected accordingly.

- NB:**
- Local flatness: 1 mm under a 20 cm rule.
 - General flatness: 5 mm under a 2 m rule.
 - Vertical trueness: 5 mm under a 2.5 m rule.
 - Mean hardness: 45 shore C.
 - Moisture < 5 % by weight.

2 - PREPARING THE WALL

Substrates must have no trace of damp, mould or marks (marker lines, ink, pencil, graffiti, etc.).

A primer compatible with the substrate and adhesive will be applied to have a regular uniform porosity.

Preparation for overlapping the coving:

The difference in thickness is made up for by feathering with filler or a feathering profile.

3 - FIXING

3.1 - Cutting the material

3.1.1 - Vertical laying

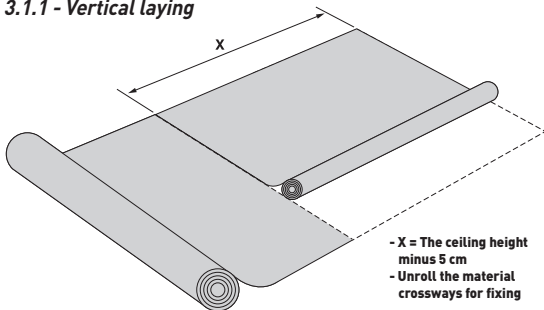

3.1.2 - Horizontal laying

Horizontal laying need to pre cut the rolls at the width and the length need before applying it.

3.2 - Fixing the material

- Leave the wall to relax at the room temperature for 24 hours.

3.3 - Drawing the initial plumb

3.3.1 - Vertical laying

- Draw an initial plumb line positioned
- Any weld or joints must be on internal angle
- Draw a second vertical at the width of a panel to determine the area to be glued.

3.3.2 - Horizontal laying

Draw an initial plumb at the high that you need and depending of the method of finishing that you decide between the coving floor and the wall covering (overlap or weld).

3.4 - Gluing and fitting

Because of the weight of the flooring, the gluing of the wall will be realized with a high level acrylic glue.

The glue will be applied uniformly with a finely notched spatula type A4 (specification TKB) with a rate of 180 - 200 gr/m², then «rolled» with a paint roller with medium «hair».

NOTE

- Closely follow the adhesive manufacturer's instructions with particular regard to its waiting time.
- Consumption and spatula are recommended by Gerflor.
- Room temperature and humidity, sub-floor absorption and adhesive consumption are important to have a perfect adhesion.
- Too short waiting time and bubbling will occur.
- Too long waiting time will result in poor transfer of the adhesive to the flooring (Schema).
- Do not overlap two films of adhesive when resuming gluing.
- Apply the first panel on the plumb line, apply the following ones.

3.5 - Installing in angles

3.5.1 - Internal angle: 1

Glue a CA 12 welding rope in the angle before installing MURAL ULTRA, MURAL CLUB or MURAL CALYPSO.

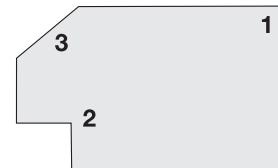

3.5.2 - External angle straight(right): 2

The wall covering have a risk to have a blushing effect

We recommend:

- Or to cut on the angle and fix by screwing on a stainless steel corner protection piece (See chapter 3.8.7).
- or to bend the angle with a stone rope or a paper rope before gluing the wall covering.

3.5.3 - Rounded external angle:

If the external angles are rounded or created with external angle profiles, the MURAL ULTRA, MURAL CLUB or MURAL CALYPSO cladding can be glued and applied without cutting.

3.5.4 - Obtuse angle (> 90°): 3

For obtuse angles (>90°), Dispersion-based contact adhesive eg.Uzin WK 222. is recommended to prevent loss of adherence over time. and or specific double side tape adhesif recommended by Gerflor (Remur from Uzin/ Sifloor). Don't use any solvent base neopren adhesive.

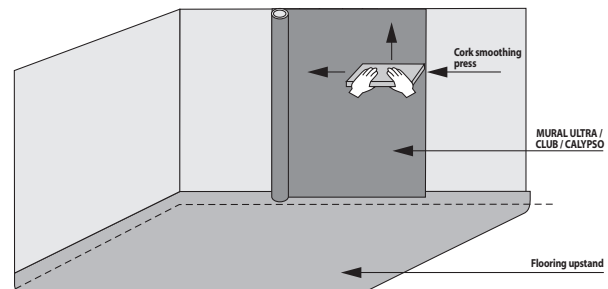

FLOORS IN BUILDINGS

[403] LAYING TECHNIQUES FOR MURAL ULTRA / MURAL CLUB / MURAL CALYPSO

3.6 - ROLLING OUT

Eliminate air starting from an edge half way up the panel using a pressure block.

3.6.1 - External angle:

- Stick down up to the angle.
- Press the material into the angle and cut or warm a little bit the wallcovering to turn around the angle.

3.6.2 - Internal angle:

- The wallcovering take is place on the CA 12 coving profile.
- Stick down the material up to the angle.
- Fold it back on itself to follow the shape of the bead.
- Fix the material using an angle roller.

3.7 - Junction with the floorcovering

3.7.1 - Overlapping the coving

The cladding overlaps the flooring coving (upstand) by at least 3 cm. The MURAL ULTRA, MURAL CLUB or MURAL CALYPSO is stuck to the coving with an acrylic adhesive.

- 1 - The MURAL ULTRA, MURAL CLUB or MURAL CALYPSO is feathered by using filler or a feathering profile.
- 2 - The cladding is protected at 3 cm under the overlap with masking tape.
- 3 - Adhesive is applied up to the masking tape; remove the masking tape before fixing the MURAL ULTRA / CLUB / CALYPSO; the overlap is applied to the upstand by heating with a paint stripper gun and sticking down with a flat roller.

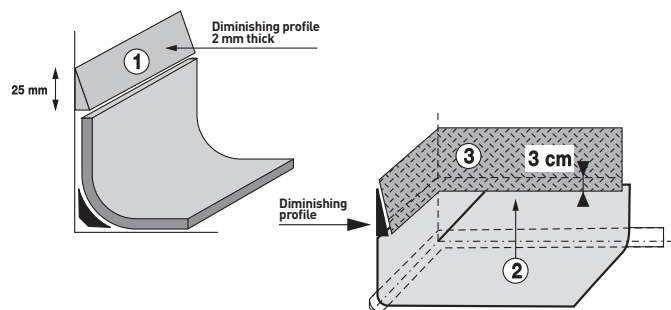

3.7.2 - Welding with the floor coving

This solution is possible ONLY with MURAL ULTRA and an homogeneous or heterogeneous product (quiet same thickness).

It need to eliminate all the residu of glue in the chanfer with the triangular groover and to have a perfect welding fusion to secure the weld in long term. Use the Rapid ultra nozzle. Follow the recommandation give in the topics 3.7.3.

3.7.3 - Treatment of joints

FIXING LENGTHS	MURAL ULTRA, MURAL CLUB OR MURAL CALYPSO: SPACING BETWEEN LENGTHS: 1 MM + 0.5 - 0MM		
	TOOLS	USE	COMMENTS
CHAMFERING	Ensure that joints are even. Eliminate traces of adhesive that stop the welding bead from fusing		
	Triangular scraper	Angle the triangular scraper so that each edge is chamfered separately and identically Chamfering may require several passes.	The recommended tools are available from Gerflor, Janser, Romus or Wolff
WELDING CR40 / MURAL ULTRA / CLUB CR41 / MURAL CALYPSO	Hot Jet S or Leister Triac type fitted with an Ultra Fast nozzle Ref.: Gerflor 0563 0001	CR 40 or CR 41 welding rope: Air gun: Hot Jet S: position 4 (80 l of air / mn) - Leister Triac:230 l of air / mn Temperature: 450 to 500°, position between 4 and 5	
MAKING FLUSH	Sum levelling spatula Mozart levelling spatula 1/4 moon cutter + levelling guide	A levelling spatula sharpened in the middle levels only the bead and avoids cutting the material	

3.8 - Finishing – connection with building's fittings

MURAL ULTRA, MURAL CLUB or MURAL CALYPSO should be glued, cut and finished around fittings with particular care and in accordance with our recommendations.

3.8.1 - Sealing jonction between Mural Ultra / Ceiling

Sealant - Ref : POLYMER MS 107
minimum 8 mm width on each part (ceiling/wall).

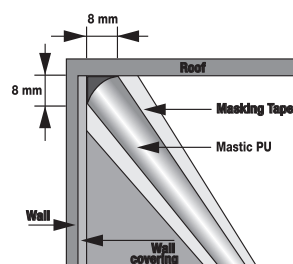

3.8.2 - Wall fitting

Wash basin, sink, external angle protection, trap door :

Sealant
ref : POLYMER MS 107

3.8.3 - Wall breaches (heating, plumbing)

Water pipes: shower, wash basin – Waste pipes - Heating: Sealant

3.8.4 - Door & window frames

Door & window frames: Sealant

3.8.5 - Electricity

Switch - Socket

See current local standards

Minimum distance (in France) for an electric point from a fixed shower head or shower hose feed: 1.20 m

3.8.6 - Ventilation

Natural: low inlet/high outlet. Mechanical – wall outlet: Sealant

3.8.7 - External angle protection

